

100 DORIN®

1918  2018

A LEGEND IN PROGRESS

VS / 2S-VS SERIES

HFC APPLICATION
169,5 to 2882 cm³



81VS-90VS RANGE

OPEN TYPE COMPRESSORS
COMPRESSORI TIPO APERTO
COMPRESSEURS TYPE OUVERT
OFFENE HUBKOLBENVERDICHTER

■ Introduzione / Introduction / Introduction / Einführung	3
■ Limiti d'applicazione / Application limits / Champs d'application / Einsatzgrenzen	4
■ Caratteristiche tecniche / Technical data / Caracteristiques techniques / Technische merkmale	6
■ Accessori / Accessories / Accessoires / Zubehör	6
■ Prestazioni / Performances Data / Données de puissance / Leistungswerte	8
R134a	8
R404A / R507	9
R22	10
2S-VS R404A / R507	11
2S-VS R22	11
■ Ingombri / Overall dimensions / Encombrements / Abmessungen	12

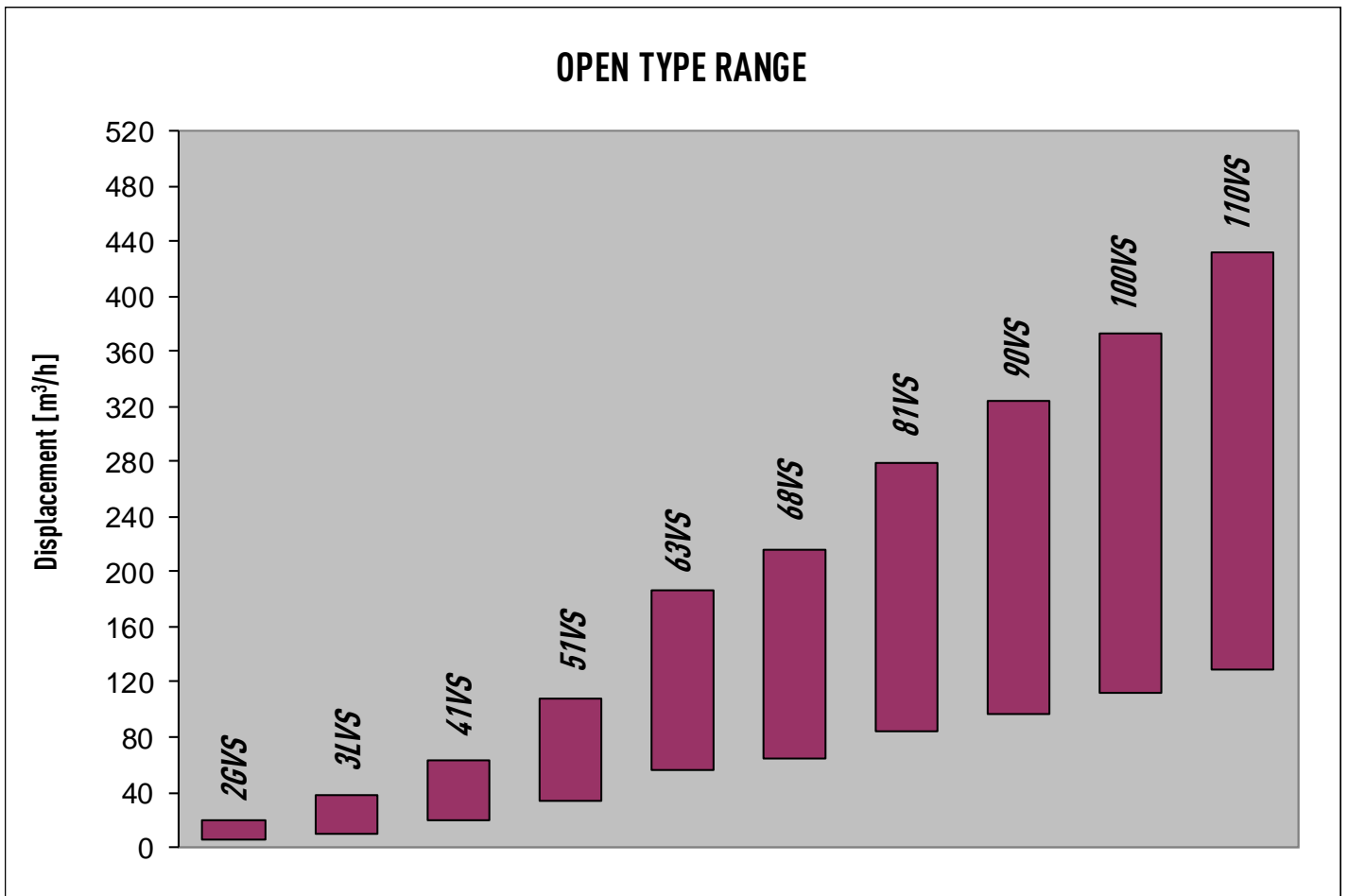

DORIN S.p.A. produce compressori aperti dal 1932.

Tali compressori sono costruiti con materiali di prima qualità e sono quindi adatti a funzionamenti in condizioni particolarmente gravose.

I compressori sono progettati per offrire il massimo delle prestazioni e particolare cura è stata data alla riduzione della rumorosità.

I compressori dal 2GVS al 51VS sono realizzati senza pompa dell'olio, e lubrificati tramite disco di centrifugazione. Questi modelli possono ruotare in un solo senso di rotazione, chiaramente indicato sulla macchina.

I compressori dal 63VS al 110VS sono lubrificati tramite una pompa a lobi ad alta pressione. Questi modelli possono ruotare in entrambe i sensi di rotazione.

Tutti i compressori aperti fabbricati da DORIN S.p.A. possono essere forniti in accordo alla direttiva 2014/34/UE – ATEX.

NOTA IMPORTANTE

Sono esclusi dalla certificazione ATEX tutti i componenti di trasmissione del moto (i.e. cinghie, carter copri-cinghie, ...) e alcuni eventuali componenti elettrici forniti di compendio.

Sul compressore è riportata la seguente marcatura ATEX:

DORIN S.p.A. has been producing open compressor since 1932.

These compressors are constructed with the highest quality materials and are therefore suitable for working in particularly hard conditions.

Compressors are designed to offer top performance and special care has been given to have smooth and silent operation.

Compressors ranging between 2GVS and 51VS are lubricated via a sling disk. Those models can rotate only in a specific rotational sense, clearly marked on the compressor.

Compressors ranging between 63VS and 110VS are lubricated via a gear oil pump. Those models can rotate in both senses.

All open type compressors manufactured by DORIN can be provided in accordance to Directive 2014/34/UE – ATEX.

IMPORTANT NOTE

ATEX approval is excluding all mechanical components including but not limited to drive belts, inherent cases, and some electric components supplied with the compressor.

Each compressor shows following ATEX marking:

Dorin S.p.A. produit des compresseurs ouverts depuis 1932.

Ces compresseurs sont réalisés avec des matériaux de première qualité, ils sont donc indiqués pour un fonctionnement dans les conditions les plus délicates.

Les compresseurs ont été conçus pour offrir le maximum des prestations, et une attention particulière a été consacrée au contrôle du niveau de bruit.

Les compresseurs du 2GVS au 51VS sont réalisés sans pompe de l'huile, et ils sont lubrifiés par un disque de centrifugation. Ces modèles peuvent tourner seulement dans un sens de rotation, clairement indiqué sur la machine.

Les compresseurs du 63VS au 110VS sont lubrifiés par une pompe à lobe à haute pression. Ces modèles peuvent tourner dans les deux sens de rotation.

Tous les compresseurs ouverts réalisés par DORIN S.p.A. peuvent être fournis conformément à la directive 2014/34/UE – ATEX.

NOTE IMPORTANTE

La certification ATEX ne concerne aucune des pièces de transmission de mouvement (courroies, carters couvre-courroies, etc.) ni des composants électriques qui pourraient être fournis comme équipement.

Dans ce cas-là, sur le moto-compresseur est lisible le marquage ATEX ci-dessous :

Seit 1932 produziert die Firma **DORIN S.p.A.** offene Verdichter.

Diese Verdichter werden aus erstklassigen Materialien hergestellt und sind daher auch unter äußerst schwierigen Bedingungen einsetzbar.

Die Verdichter werden speziell dafür entwickelt, höchsten Anforderungen gerecht zu werden, wobei besonderer Wert auf die Lärmreduzierung gelegt wurde.

Die Verdichtermodelle 2GVS bis 51VS werden ohne Ölpumpe hergestellt und durch eine Schleuderscheibe geschmiert. Diese Modelle können nur in einer, auf der Maschine klar ausgezeichneten Drehrichtung laufen.

Die Verdichtermodelle 63VS bis 110VS werden mit einer Kreiskolbenpumpe unter hohem Druck geschmiert. Diese Modelle können in beide Richtungen drehen.

Alle offenen, von DORIN S.p.A. hergestellten Verdichter können gemäß der Richtlinie 2014/34/UE – ATEX geliefert werden.

WICHTIGER HINWEIS

Ausgeschlossen von der ATEX-Zertifizierung sind alle Komponenten der Bewegungsübertragung des Verdichters (d.h. Riemen, Riemenabdeckung, ...) und etwaige als Zubehör gelieferte Elektrokomponenten.

In diesem Fall hat der Verdichter folgende ATEX-Kennzeichnung:



II = apparecchio del gruppo II

3 = categoria 3 (zona 2)

G = atmosfera esplosiva con presenza di gas, vapori o nebbie

c = modo di protezione apparecchiature non elettriche (sicurezza costruttiva)

IIB = gruppo di gas

X = Condizioni particolari per l'utilizzo sicuro:

- rischio meccanico basso
- Tamb: -20°C ÷ +60°C

• classe di temperatura T3 o T4 in accordo alle condizioni di lavoro. L'utilizzatore deve desumere la temperatura massima superficiale dell'attrezzatura in funzione dell'applicazione, individuandola come riportata nei seguenti diagrammi di applicazione.

II = group II machinery

3 = category 3 (zone 2)

G = explosive atmosphere with gas, vapor or fog presence

c = protection type for non-electric equipment (constructive safety)

IIB = gas group

X = Special conditions for safe use:

- low mechanical risk
- Tamb: -20°C ÷ +60°C

• temperature class T3 or T4 according to the working condition. Temperature class can anyway be identified considering the given application, caring about what mentioned in the following application envelopes.

II = dispositif du groupe II

3 = catégorie 3 (zone 2)

G = atmosphère explosive à la présence de gaz, de vapeurs ou de brouillards

c = mode de protection appareillages non électriques (sécurité constructive)

IIB = groupe de gaz

X = Conditions spéciales pour une utilisation sûre:

- faible risque mécanique
- Tamb: -20°C ÷ +60°C

• classe T3 ou T4 de température selon l'état de marche. L'utilisateur doit déduire la température maximale superficielle de l'installation en fonction de l'application, la calculant selon les indications des diagrammes d'application ci-dessous.

II = Maschine der Gruppe II

3 = Kategorie 3 (Zone 2)

G = explosive Umgebung für Gase und Stäube

c = Sicherheitsklasse für nicht elektronische Ausrüstung (Sicherheit am Bau)

IIB = Gasgruppe

X = Besondere Bedingungen für die sichere Anwendung:

- geringe mechanische Risiko
- Tamb: -20°C ÷ +60°C

• Temperaturklasse T3 oder T4 gemäß der Arbeitsbedingung. Der Benutzer bestimmt die maximale Oberflächentemperatur des Geräts nach der jeweiligen Anwendung anhand der im folgenden aufgeführten Diagramme.

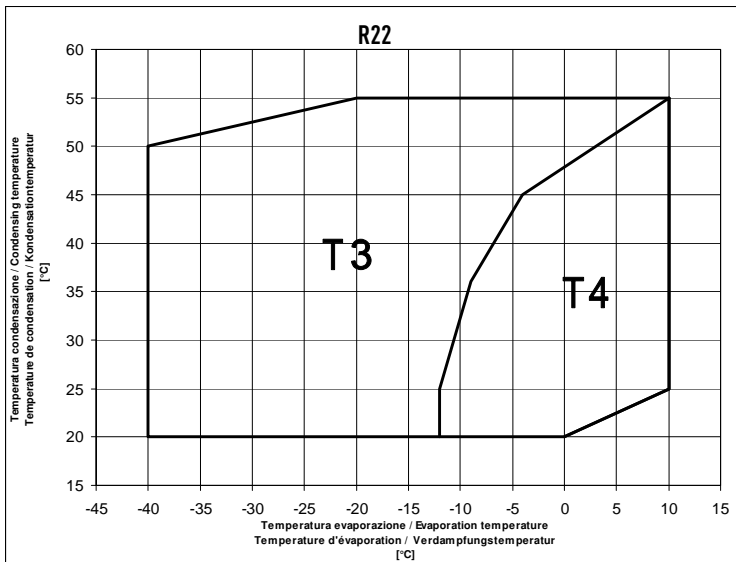
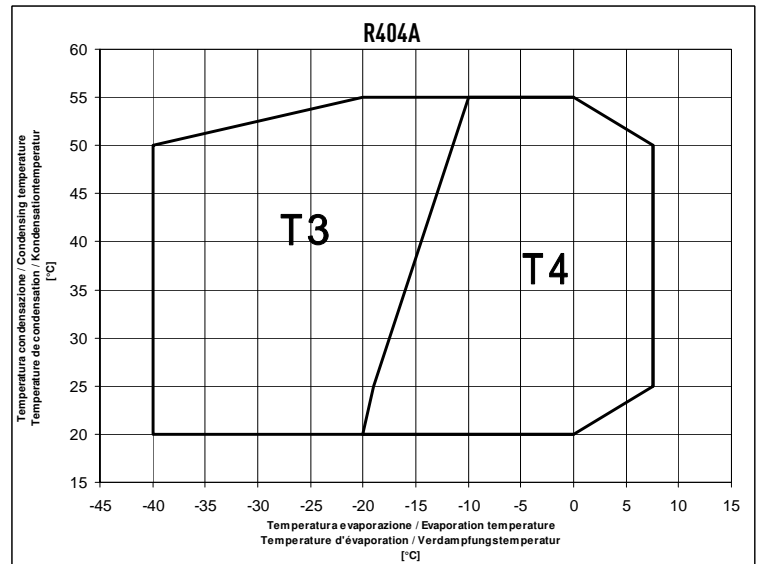
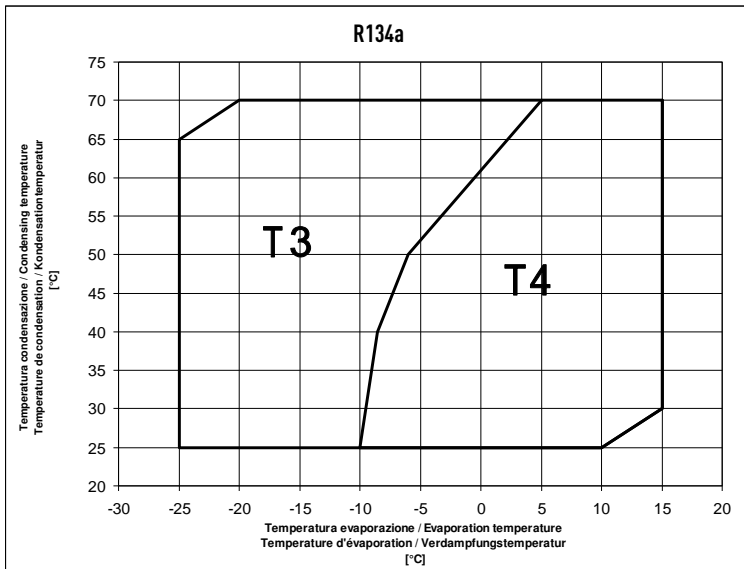

T3 massima temperatura superficiale 200°C

T4 massima temperatura superficiale 135°C

Surriscaldamento in aspirazione < 30K

T3 maximum surface temperature 200°C

T4 maximum surface temperature 135°C

Suction gas superheat < 30K

T3 température de surface maximale 200°C

T4 température de surface maximale 135°C

Surchauffe à l'aspiration < 30K

T3 maximale Oberflächentemperatur 200°C

T4 maximale Oberflächentemperatur 135°C

Sauggas-Überhitzung < 30K

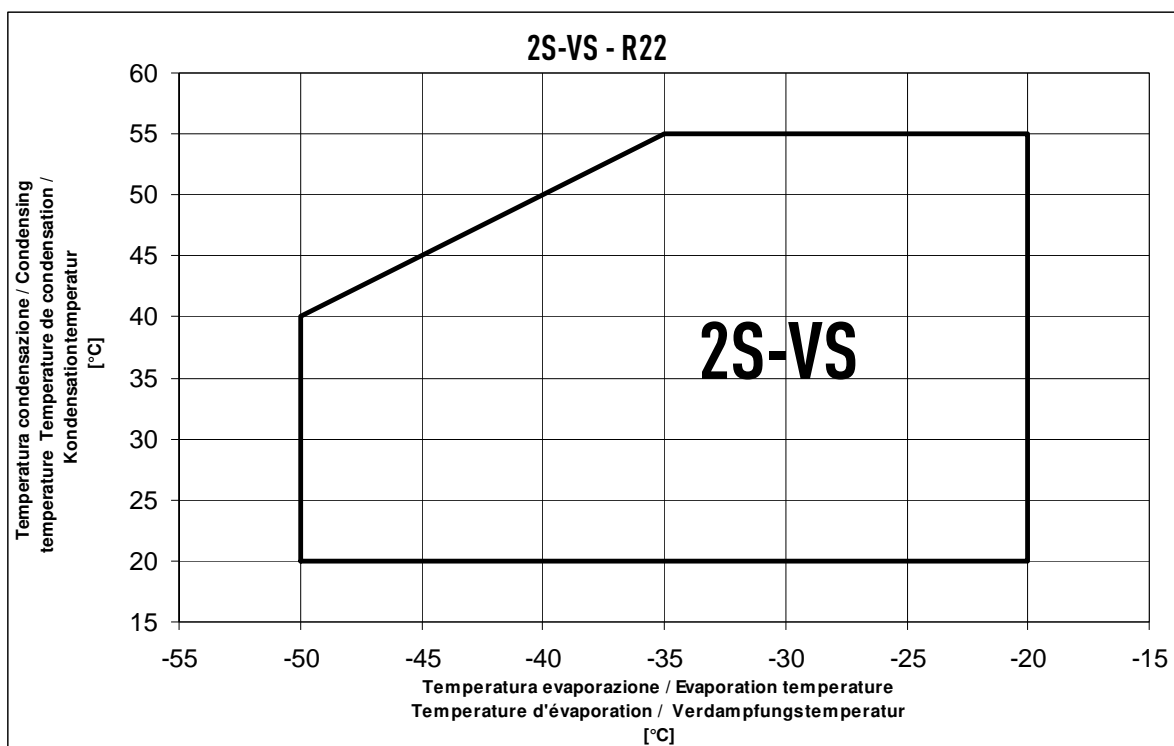
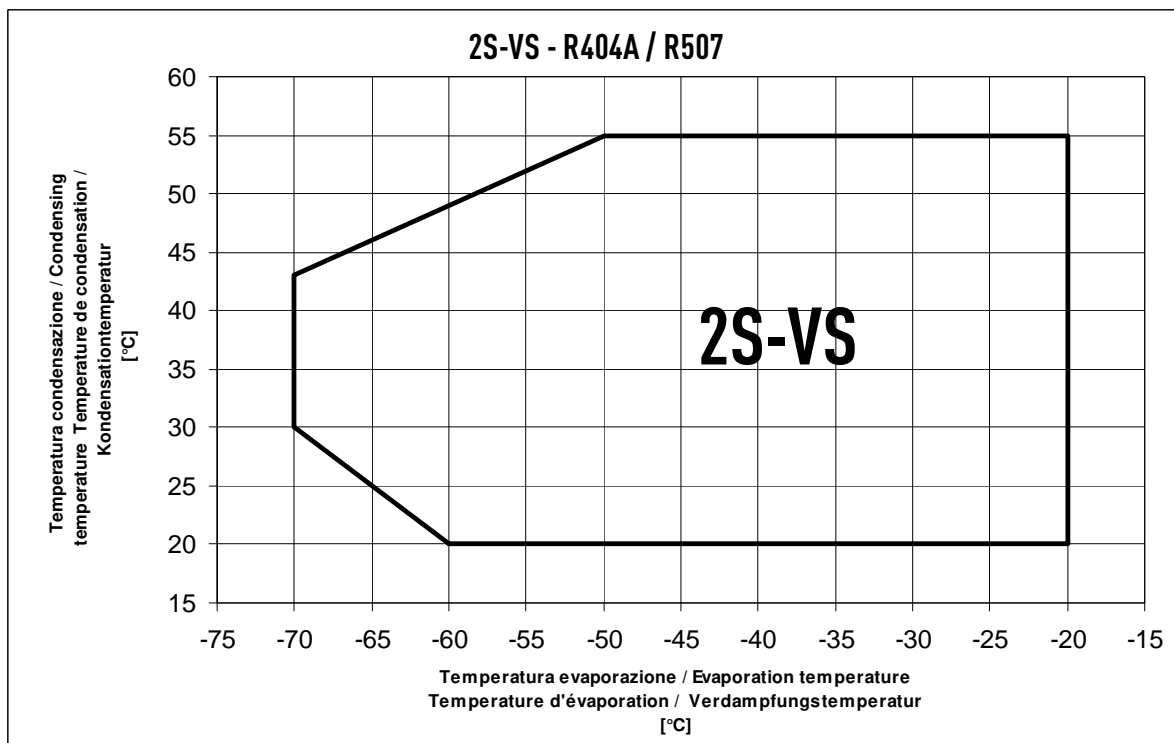

- Utilizzo con R22 solo dove permesso dalle legislazioni nazionali
- Use with R22 only where permitted by national legislation
- Utiliser avec R22 seulement lorsque cela est autorisé par la législation nationale
- Utiliser avec R22 seulement lorsque cela est autorisé par la législation nationale

Modello Model Modèle Typ	Cil. Cyl. Zyl.	Alesaggio Bore Alésage Bohrung	Corsa Stroke Course Hub	Cilindrata Swept volume Cylindrée Hubvolumen	Vol. Spost. Displacement Volume bal. Fördervolumen	Aspirazione Suction Aspiration Saugventil	Scarico Discharge Refoulement Druckventil	Volano Flywheel Volant Schwungrad	Carica olio Oil charge Charge huile Ölfüllung	Peso Weight Poids Gewicht	giri/1' r.p.m. tr / mn u.p.m.		Potenza assorbita Power input Puissance absorbée Leistungsaufnahme
	n	[mm]	[mm]	[cm ³]	[m ³ /h]	SL [mm]	DL [mm]	[mm] *	[kg]	[kg] **	min	max	HP
	2GVS	2	60	30	169,5	14,75 @ 1450	3/4" - 18	5/8" - 16	160-2A	1,0	22	500	1450
3LVS	2	61	60	350,7	27,35 @ 1300	28s	3/4" - 18	270-3A	1,5	38	500	1300	4 - 15
41VSR	2	74	65	560,0	43,68 @ 1300	28s	22s	303-3B	3,0	78	600	1300	5.5 - 20
41VSM/3B	2	74	65	560,0	43,68 @ 1300	35s	28s	303-3B	3,0	78	600	1300	5.5 - 20
41VSM/4B	2	74	65	560,0	43,68 @ 1300	35s	28s	303-4B	3,0	82	600	1300	5.5 - 20
51VSR	2	88	78	949,0	74,02 @ 1300	35s	28s	335-4B	4,0	118	600	1300	10 - 30
51VSM	2	88	78	949,0	74,02 @ 1300	42s	35s	335-4B	4,0	118	600	1300	10 - 30
63VS/4B	4	78	65	1245,0	108,32 @ 1450	42s	2 x 28s	310-4B	5,5	156	750	1750	15 - 50
63VS/6B	4	78	65	1245,0	108,32 @ 1450	42s	2 x 28s	310-6B	5,5	156	750	1750	15 - 50
63VSC/6B	4	78	65	1245,0	108,32 @ 1450	42s	35s	310-6B	5,5	156	750	1750	15 - 50
68VS/4B	4	84	65	1440,0	125,28 @ 1450	54s	35s	310-4B	5,5	156	750	1750	15 - 75
68VS/6B	4	84	65	1440,0	125,28 @ 1450	54s	35s	310-6B	5,5	156	750	1750	15 - 75
81VS	6	78	65	1865,0	162,26 @ 1450	54s	42s	310-6SPB	6,5	203	750	1750	15 - 100
90VS	6	84	65	2160,0	187,92 @ 1450	54s	42s	310-6SPB	6,5	203	750	1750	15 - 100
100VS	8	78	65	2485,0	216,20 @ 1450	80s	54s	310-6SPB	8,5	240	750	1750	20 - 125
110VS	8	84	65	2882,0	250,73 @ 1450	80s	54s	310-6SPB	8,5	240	750	1750	20 - 125

FW Volano Flywheel Volant Schwungrad	CH Resistenza carter Crankcase heater Résistance carter Olsumpheizung	BF Ventilatore su testa Head fan Ventilation auxiliaire Zylinderkopfkühlung
WH Teste raffreddate ad acqua Water cooled head Tête refroidie à eau Wasserkühlung des Zylinderkopfes	CR Regolazione di potenza Capacity control Régulateur de puissance Leistungsregler	US Partenza a vuoto Unloaded start Démarrage à vide Anlaufentlastung

Modello - Model Modèle - Typ	FW *	CH *	BF	WH *	CR *	US *
2GVS	B	B				
3LVS	B	B	B			
41VSR	B	B	B	B		
41VSM/3B	B	B	B	B		
41VSM/4B	B	B	B	B		
51VSR	B	B	B	B		
51VSM	B	B	B	B		
63VS/4B	B	B	B	B	B	B
63VS/6B	B	B	B	B	B	B
63VSC/6B	B	B	B	B	B	B
68VS/4B	B	B	B	B	B	B
68VS/6B	B	B	B	B	B	B
81VS	B	B	B	B	B	B
90VS	B	B	B	B	B	B
100VS	B	B	B	B	B	B
110VS	B	B	B	B	B	B
2S-81VS	B	B	B	B	B	B
2S-90VS	B	B	B	B	B	B

* Disponibili per versione ATEX / Available for ATEX version / Disponible pour la version ATEX / Verfügbar für ATEX-Ausführung

B Accessori su richiesta / Optional accessories / Accessoires sur demande / Zubehörteile auf Wunsch

Modello Model Modèle Typ	Numero Cilindri Number of Cylinders Nombre cylindres Anzahl der Zylinder		Alesaggio Bore Alésage Bohrung	Corsa Stroke Course Hub	Cilindrata Swept volume Cylindrée Hubvolumen		Vol. Spost. Displacement Volume bal. Fördervolumen		Aspirazione Suction Aspiration Saugventil	Scarico Discharge Refoulement Druckventil	Volano Flywheel Volant Schwungrad	Carica olio Oil charge Charge huile Ölfüllung	Peso Weight Poids Gewicht	giri/1' r.p.m. tr / mn u.p.m.		Potenza assorbita Power input Puissance absorbée Leistungsaufnahme
	LP	HP	[mm]	[mm]	LP	HP	LP	HP	SL [mm]	DL [mm]	[mm] *	[kg]	[kg] **	min	max	HP
			[mm]	[mm]	[cm ³]		[m ³ /h] @ 1450									
2S-81VS	4	2	78	65	1242	621	108,05	54,03	54s	42s	310-6SPB	6,5	216	750	1750	15 - 100
2S-90VS	4	2	84	65	1440	720	125,28	62,64	54s	42s	310-6SPB	6,5	216	750	1750	15 - 100

* Tipi di cinghie / Belts types / Type de courroies / Riementypen

** Peso lordo con volano / Gross weight with flywheel / Poids brut avec volant / Bruttogewicht mit schwungrad

2S-VS

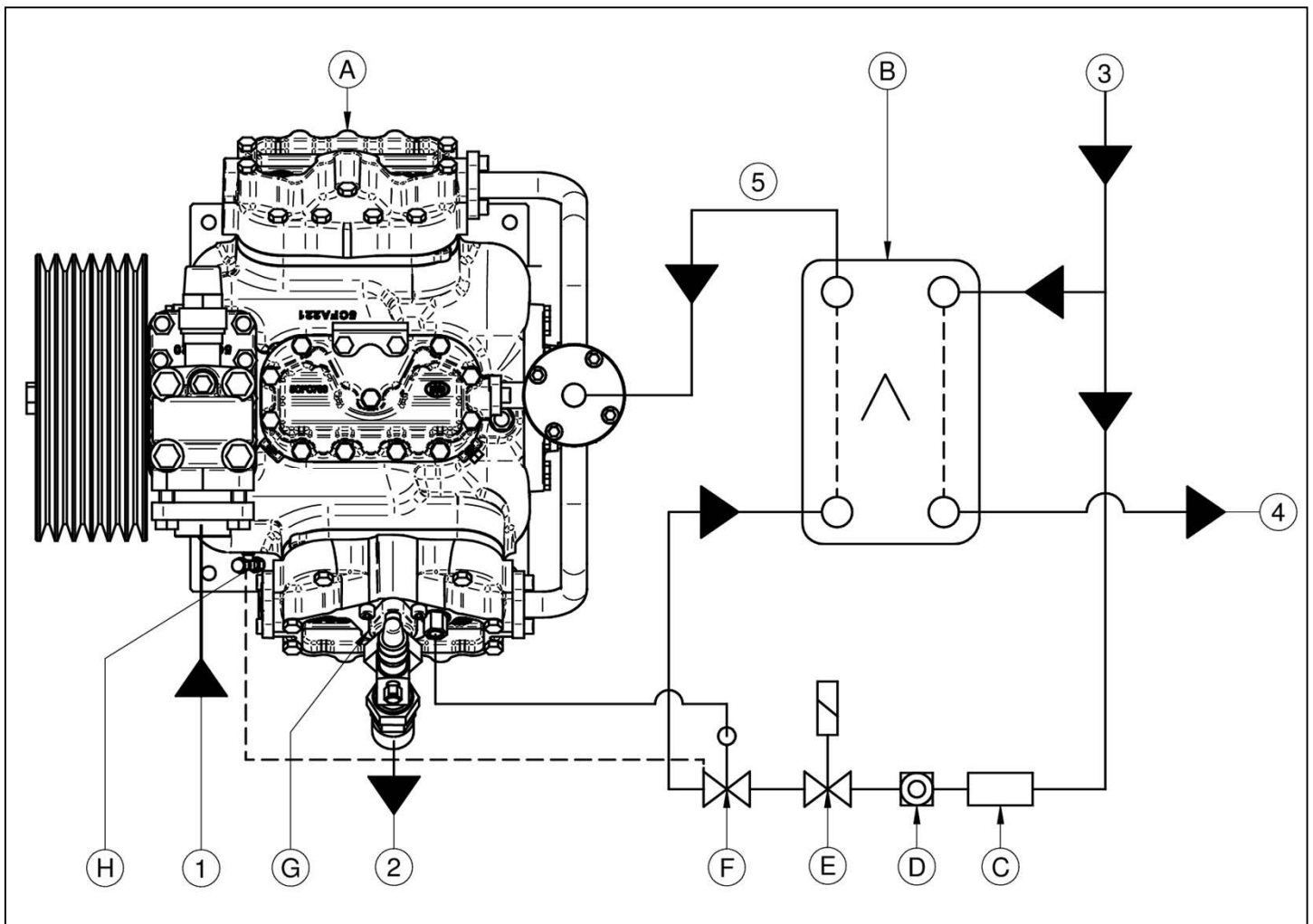

A - Compressore B - Sottoraffreddatore liquido C - Filtro D - Spia liquido E - Valvola solenoide F - Valvola termostatica G - Valvola di ritegno H - Presa Bassa Press.	A - Compressor B - Liquid subcooler C - Filter D - Indicateur E - Solenoid valve F - Expansion valve G - Non return valve H - Low pressure tap	A - Compresseur B - Sous-refroidisseur de liquide C - Filtre D - Indicateur E - Soupape solénoïde F - Détendeur thermostatique G - Soupape de retenue H - Prise basse pression	A - Verdichter B - Kältemittel-Unterkühler C - Filter D - Indikatoren E - Magnetventil F - Expansionsventil G - Rückschlagventil H - Anschluss Niederdruck
1 - Dall'evaporatore 2 - Al condensatore 3 - Dalla linea del liquido 4 - All'evaporatore 5 - All'aspirazione del II stadio	1 - From evaporator 2 - To condenser 3 - From liquid line 4 - To evaporator 5 - To II stage suction	1 - Du évaporateur 2 - Au condenseur 3 - Du ligne de liquide 4 - Au évaporateur 5 - Au aspiration du II étages	1 - Vom Verdampfer 2 - Zum Kondensator 3 - Vom Flüssigkeitsleitung 4 - Zum Verdampfer 5 - Zum Saugventil II stufiges

R134a

Modello Model Modèle Typ	giri/1' r.p.m. tr / mn u.p.m.	Cilindrata Swept volume Cylindrée Hubvolumen	HP-CV-PS*			Temp. Cond. Cond. Temp. Temp. Cond. Kond. Temp.	Q [W]	Capacità frigorifera - Refrigerating capacity Puissance frigorifique - Kälteleistung					
			Potenza da installare Power to install Puissance à installer Zu installierende Leistung					Temperatura evaporazione / Evaporating temperature Température d'évaporation / Verdampfungstemperatur [°C]					
			C	S	B			C		S		B	
			[cm³]					+10	+5	0	-5	-10	-15
2GVS	800	170	3	2	2	35	6500	5330	4300	3420	2660	2020	1490
			4	3	2	45	5710	4660	3750	2960	2290	1730	1250
			4	3	2	55	4960	4040	3240	2560	1980	1480	1060
	1000		3	3	3	35	8130	6660	5380	4270	3330	2530	1860
			4	3	3	45	7130	5820	4680	3700	2870	2160	1560
			4	3	3	55	6200	5050	4050	3200	2470	1850	1320
1450	4	3	3	35	11780	9650	7790	6190	4820	3660	2690		
	5,5	4	3	45	10340	8440	6790	5370	4150	3130	2260		
	5,5	4	3	55	8990	7320	5880	4640	3580	2680	1920		
3LVS	800	351	7,5	5,5	4	35	12770	10590	8700	7060	5660	4470	3480
			7,5	5,5	4	45	11120	9200	7530	6100	4870	3830	2960
			10	5,5	4	55	9530	7860	6420	5180	4130	3230	2470
	1000		7,5	5,5	4	35	15960	13240	10870	8820	7070	5590	4350
			7,5	5,5	4	45	13900	11500	9420	7620	6090	4790	3700
			15	5,5	4	55	11910	9830	8030	6480	5160	4040	3090
1200	5,5	7,5	5,5	35	19150	15880	13040	10590	8490	6710	5220		
	7,5	7,5	5,5	45	16680	13800	11300	9140	7300	5740	4430		
	7,5	7,5	5,5	55	14290	11790	9630	7770	6190	4840	3700		
41VSR 41VSM/3B 41VSM/4B	800	560	10	7,5	5,5	35	22400	18350	14830	11780	9180	6970	5120
			10	10	7,5	45	19640	16030	12890	10190	7880	5920	4270
			15	10	7,5	55	17030	13860	11110	8750	6730	5020	3570
	1000		15	7,5	5,5	35	28000	22940	18530	14730	11470	8710	6400
			15	15	7,5	45	24550	20030	16110	12730	9840	7400	5330
			15	15	7,5	55	21290	17320	13890	10930	8410	6270	4460
1200	15	10	7,5	35	33600	27530	22240	17670	13760	10460	7680		
	15	15	10	45	29460	24040	19330	15280	11810	8870	6400		
	20	15	10	55	25550	20790	16660	13120	10090	7520	5350		
51VSR 51VSM	800	949	15	15	10	35	37470	30810	25020	20030	15750	12140	9110
			20	10	7,5	45	33070	27130	21960	17520	13720	10500	7790
			20	10	7,5	55	28890	23650	19120	15230	11900	9080	6690
	1000		20	15	15	35	46830	38520	31280	25030	19690	15170	11380
			25	15	10	45	41340	33910	27450	21900	17150	13120	9730
			25	15	10	55	36110	29570	23900	19030	14880	11350	8360
1200	25	20	15	35	56200	46220	37530	30040	23630	18200	13660		
	25	15	15	45	49600	40690	32940	26280	20580	15750	11680		
	25	15	15	55	43340	35480	28680	22840	17850	13620	10030		
63VS/4B 63VS/6B 63VSC/6B	1000	1245	25	15	15	35	58950	48780	39940	32300	25780	20250	15630
			30	20	15	45	52030	42950	35070	28290	22490	17570	13430
			30	20	15	55	45290	37290	30380	24440	19370	15060	11410
	1450		30	20	15	35	85470	70730	57910	46840	37370	29360	22660
			40	25	20	45	75440	62280	50860	41010	32600	25480	19480
			40	25	20	55	65660	54080	44050	35440	28080	21840	16550
1750	30	25	20	35	103200	85370	69880	56530	45100	35440	27340		
	35	40	25	45	91050	75170	61380	49500	39350	30750	23500		
	40	40	25	55	79250	65260	53160	42770	33890	26360	19970		
68VS/4B 68VS/6B	1000	1440	30	20	15	35	68880	57160	46920	38030	30390	23880	18390
			30	25	15	45	60960	50370	41150	33190	26370	20590	15730
			40	25	15	55	53310	43840	35640	28600	22600	17540	13300
	1450		40	25	20	35	99870	82880	68030	55150	44070	34630	26670
			40	30	20	45	88390	73030	59660	48120	38240	29850	22800
			50	30	20	55	77300	63560	51670	41460	32770	25430	19280
1750	50	40	25	35	120600	100100	82100	66550	53180	41790	32190		
	50	40	25	45	106700	88140	72000	58070	46150	36030	27520		
	75	40	25	55	93290	76710	62360	50040	39550	30690	23270		
81VS	1000	1865	40	25	15	35	90160	74510	60880	49120	39060	30550	23420
			40	30	20	45	79300	65360	53270	42840	33940	26390	20040
			50	30	20	55	68830	56610	46030	36950	29190	22610	17030
	1450		50	30	25	35	130800	108100	88280	71220	56640	44290	33960
			50	40	25	45	115000	94780	77230	62120	49210	38270	29060
			60	40	25	55	99800	82080	66750	53570	42330	32780	24690
1750	50	40	30	35	157800	130400	106600	85950	68350	53460	40980		
	50	50	30	45	138800	114400	93210	74970	59390	46190	35070		
	60	50	40	55	120500	99060	80560	64660	51090	39560	29800		
90VS	1000	2160	40	30	25	35	103800	85890	70310	56870	45380	35660	27510
			40	40	25	45	91710	75710	61820	49860	39630	30970	23680
			50	40	25	55	79900	65800	53610	43130	34180	26580	20140
	1450		50	40	30	35	150500	124600	102000	82460	65800	51700	39890
			50	40	30	45	133000	109800	89630	72290	57470	44900	34330
			60	50	30	55	115900	95410	77730	62530	49550	38530	29200
1750	60	50	40	35	181700	150300	123100	99520	79410	62390	48140		
	60	50	40	45	160500	132500	108200	87240	69360	54190	41430		
	75	60	40	55	139900	115200	93810	75470	59810	46500	35230		
100VS	1000	2485	40	30	25	35	119400	98630	80560	64970	51630	40350	30890
			40	40	25	45	104900	86450	70440	56640	44850	34860	26460
			50	40	25	55	91020	74860	60880	48880	38620	29920	22540
	1450		50	40	30	35	173100	143000	116900	94200	74860	58500	44790
			60	50	40	45	152200	125400	102200	82130	65040	50550	38360
			75	50	40	55	132000	108600	88280	70870	56000	43380	32690
1750	60	50	40	35	208900	172600	141000	113700	90350	70600	54060		
	75	60	40	45	183600	151300	123300	99120	78490	61010	46290		
	100	60	40	55	159300	131000	106600	85530	67590	52350	39450		
110VS	1000	2882	40	40	25	35	137300	113600	92910	75120	59910	47030	36250
			50	40	30	45	121200	100000	81640	65820	52310	40850	31210
			50	40	30	55	105600	86900	70800	56970	45150	35120	26620
	1450		60	50	40	35	199000	164700	134800	109000	86860	68190	52560
			75	60	40	45	175700	145000	118400	95440	75850	59240	45260
			100	60	40	55	153000	126100	102700	82600	65470	50920	38600
1750	75	60	50	35	240200	198700	162600	131500	104900	82300	63430		
	80	75	50	45	212100	175000	142900	115200	91540	71490	54620		
	100	75	50	55	184700	152100	123900	99690	79020	61460	46590		

- Le prestazioni si basano sulla norma europea EN12900
 - Temperatura di aspirazione = 20°C per R134a, R404A, R22 (5 K surriscaldamento per R717)
 - Sottoraffreddamento = 0K
 - * Potenza consigliata
-
- Performance data are based on European Standard EN12900
 - Suction gas temperature = 20°C for R134a, R404A, R22 (5 K suction gas superheat for R717)
 - Liquid subcooling = 0K
 - * Recommended power
-
- Les données de puissance se basent sur la norme européenne EN12900
 - Température de gaz aspiré = 20°C pour R134a, R404A, R22 (5 K surchauffe à l'aspiration pour R717)
 - Sous-refroidissement = 0K
 - * Puissance recommandée
-
- Leistungswerte basieren auf der europäischen Norm EN 12900
 - Sauggasttemperatur = 20°C bei R134a, R404A, R22 (5 K Sauggas-Überhitzung bei R717)
 - Flüssigkeits-Unterkühlung = 0K
 - * Empfohlen Leistung

Modello Model Modèle Typ	giri/1' r.p.m. tr / mn u.p.m.	Cilindrata Swept volume Cylindrée Hubvolumen [cm ³]	HP-CV-PS*			Temp. Cond. Cond. Temp. Temp. Cond. Kond. Temp. [°C]	Q [W]	Capacità frigorifera - Refrigerating capacity Puissance frigorifique - Kälteleistung								
			Potenza da installare Power to install Puissance à installer Zu installierende Leistung					Temperatura evaporazione / Evaporating temperature Température d'évaporation / Verdampfungstemperatur [°C]								
			C	S	B			C			S			B		
								+5	0	-5	-10	-15	-20	-25	-30	-35
2GVS	800	170	4	3	3	30	9090	7660	6390	5280	4320	3490	2770	2170	1660	1240
			4	3	2,5	40	7730	6490	5390	4430	3600	2880	2270	1750	1300	920
			4	3	2,5	50	6350	5300	4370	3570	2870	2270	1760	1320	935	605
			4	4	4	30	11360	9570	7990	6600	5400	4360	3470	2710	2080	1550
	1000		4	4	3	40	9660	8110	6740	5540	4500	3600	2840	2180	1620	1150
			4	4	3	50	7940	6620	5460	4460	3590	2840	2200	1650	1170	755
			7,5	5,5	4	30	16470	13870	11580	9570	7820	6310	5020	3930	3010	2240
			7,5	7,5	5,5	40	14010	11750	9770	8030	6520	5220	4110	3160	2350	1670
	1450		7,5	7,5	5,5	50	11510	9590	7920	6460	5200	4120	3190	2390	1700	1100
			5,5	5,5	4	30	18990	16020	13400	11100	9110	7390	5910	4660	3610	2730
			7,5	5,5	4	40	16520	13900	11590	9580	7830	6320	5030	3930	2990	2190
			10	7,5	5,5	50	13940	11680	9700	7980	6490	5210	4110	3170	2350	1640
3LVS	800	351	7,5	7,5	5	30	23730	20020	16750	13880	11380	9230	7390	5830	4510	3420
			10	7,5	5	40	20650	17370	14490	11970	9790	7900	6290	4910	3740	2740
			10	10	7,5	50	17420	14600	12120	9970	8110	6510	5140	3960	2940	2050
			10	7,5	7,5	30	28480	24020	20090	16650	13660	11080	8870	6990	5420	4100
	1000		15	10	7,5	40	24780	20850	17390	14370	11750	9480	7550	5890	4480	3290
			15	10	7,5	50	20900	17510	14550	11970	9730	7810	6160	4750	3530	2460
			10	10	7,5	30	30420	25590	21330	17600	14350	11550	9150	7110	5400	3970
			15	10	7,5	40	26220	22000	18280	15020	12200	9770	7680	5900	4390	3100
	1200		15	15	7,5	50	21940	18320	15160	12400	10020	7970	6210	4700	3400	2270
			15	15	10	30	38020	31990	26670	22000	17940	14430	11430	8890	6750	4960
			25	15	10	40	32780	27490	22840	18780	15250	12210	9600	7370	5480	3870
			15	15	15	50	27430	22900	18950	15500	12530	9960	7760	5870	4250	2830
41VSR 41VSM/3B 41VSM/4B	800	560	15	15	15	30	45630	38390	32000	26400	21520	17320	13720	10660	8100	5950
			20	20	15	40	39330	32990	27410	22530	18300	14650	11520	8850	6580	4650
			20	20	20	50	32910	27480	22740	18600	15030	11950	9310	7050	5100	3400
			20	20	20	30	51620	43430	36200	29860	24350	19590	15520	12060	9160	6730
	1000		25	20	20	40	44500	37320	31010	25490	20700	16570	13030	10010	7440	5260
			25	25	20	50	37230	31090	25720	21050	17000	13520	10540	7970	5770	3840
			20	20	20	30	64520	54290	45250	37330	30430	24490	19400	15080	11450	8420
			25	20	20	40	55620	46650	38760	31870	25880	20710	16290	12510	9300	6570
	1200		25	25	25	50	46540	38860	32150	26310	21250	16900	13170	9960	7210	4800
			25	25	25	30	77430	65140	54300	44790	36520	29380	23270	18090	13730	10100
			30	25	25	40	66750	55980	46510	38240	31050	24850	19540	15010	11160	7880
			30	30	25	50	55840	46630	38580	31570	25500	20280	15800	11960	8650	5760
51VSR 51VSM	800	949	30	20	20	30	83940	70650	58930	48660	39720	32010	25410	19810	15100	11170
			30	20	20	40	72640	60960	50680	41700	33900	27180	21410	16490	12310	8750
			40	25	25	50	60990	50950	42170	34530	27920	22220	17340	13140	9530	6400
			40	30	25	30	121800	102500	85450	70550	57590	46410	36840	28720	21890	16190
	1000		40	40	25	40	105400	88390	73490	60460	49160	39400	31040	23910	17840	12680
			50	50	30	50	88430	73880	61140	50060	40480	32220	25140	19060	13820	9270
			50	40	40	30	146900	123700	103200	85150	69510	56010	44460	34660	26420	19540
			60	50	30	40	127200	106700	88690	72970	59330	47550	37460	28850	21530	15310
	1200		75	50	40	50	106800	89170	73790	60420	48850	38890	30340	23000	16680	11190
			40	30	30	30	98140	82610	68910	56890	46440	37420	29700	23160	17650	13060
			40	40	30	40	84770	71130	59140	48660	39560	31710	24980	19240	14360	10210
			40	40	30	50	71020	59340	49110	40210	32510	25880	20190	15310	11100	7450
63VSR/4B 63VSR/6B 63VSR/6B	1000	1245	50	50	40	30	142300	119800	99910	82490	67340	54260	43070	33580	25590	18930
			60	50	40	40	123000	103200	85750	70550	57360	45980	36220	27900	20820	14800
			75	60	40	50	103000	86030	71200	58300	47140	37520	29270	22190	16100	10790
			60	60	50	30	171800	144600	120600	99560	81270	65490	51980	40520	30890	22850
	1450		75	60	50	40	148400	124500	103500	85150	69220	55490	43710	33670	25130	17860
			75	60	50	50	124300	103900	85930	70360	56890	45290	35330	26780	19430	13030
			40	40	30	30	125500	105700	88120	72770	59420	47890	38030	29660	22630	16770
			50	40	30	40	107500	90190	74990	61700	50160	40210	31680	24410	18230	12970
	1750		50	50	40	50	89250	74550	61690	50500	40820	32490	25340	19200	13910	9310
			60	50	50	30	181900	153200	127800	105600	86150	69440	55140	43010	32820	24320
			75	60	50	40	155900	130800	108800	89460	72730	58300	45940	35390	26430	18810
			75	60	50	50	129500	108100	89450	73230	59190	47110	36740	27840	20170	13490
68VSR/4B 68VSR/6B	1000	1440	75	60	60	30	219600	184900	154200	127400	104000	83810	66550	51910	39600	29350
			100	75	60	40	188100	157900	131300	108000	87780	70370	55440	42710	31890	22690
			100	75	60	50	156200	130500	108000	88370	71440	56860	44340	33590	24340	16280
			50	50	40	30	145500	122500	102200	84400	68910	55540	44100	34400	26250	19450
	1450		60	50	40	40	124700	104600	86970	71560	58180	46640	36740	28310	21140	15040
			75	50	40	50	103600	86460	71540	58570	47350	37680	29380	22270	16130	10790
			75	75	50	30	211000	177700	148200	122400	99920	80530	63950	49880	38060	28200
			90	75	60	40	180800	151700	126100	103800	84350	67620	53270	41040	30650	21810
	1750		100	100	60	50	150100	125400	103800	84920	68650	54640	42610	32280	23390	15650
			100	100	60	30	254600	214400	178900	147700	120600	97190	77180	60200	45930	34030
			100	100	70	40	218200	183100	152200	125300	101900	81610	64300	49530	36990	26320
			100	100	70	50	181200	151300	125200	102500	82850	65940	51420	38960	28230	18880
81VS	1000	1865	60	50	40	30	166100	139800	116700	96290	78620	63360	50300	39230	29930	22170
			75	60	40	40	142200	119300	99170	81590	66330	53160	41880	32260	24080	17130
			-	60	50	50	-	-	81530	66740	53950	42930	33470	25350	18360	12270
			75	75	60	30	240800	202700	169100	139700	114000	91870	72940	56890	43390	32140
	1450		100	75	60	40	206200	173000	143800	118400	96170	77090	60720	46770	34910	24830
			-	100	60	50	-	-	118300	96770	78220	62240	48530	36760	26620	17800
			100	100	75	30	290600	244600	204100	168600	137600	110900	88030	68650	52370	38790
			100	100	75	40	248800	208800	173600	142800	116100	93030	73290	56450	42140	29970
	1750		-	125	75	50	-	-	142700	116800	94400	75120	58570	44370	32130	21480
			60	60	50	30	192300	161900	135100	111600	91050	73380	58260	45440	34660	25670
			75	60	50	40	164700	138200	114900	94500	76820	61570	48500	37360	27890	19840
			-	75	50	50	-	-	94430	77300	62480	49720	38			

R22

Modello Model Modèle Typ	giri/1' r.p.m. tr / mn u.p.m.	Cilindrata Swept volume Cylindrique Hubvolumen [cm ³]	HP-CV-PS*			Temp. Cond. Cond. Temp. Temp. Cond. Kond. Temp. [°C]	Q [W]	Capacità frigorifera - Refrigerating capacity Puissance frigorifique - Kälteleistung								
			Potenza da installare Power to install Puissance à installer Zu installierende Leistung					Temperatura evaporazione / Evaporating temperature Température d'évaporation / Verdampfungstemperatur [°C]								
			C	S	B			C		S			B			
								+5	0	-5	-10	-15	-20	-25	-30	-35
2GVS	800	170	3	2	2	30	8570	7170	5940	4870	3950	3150	2470	1890	1410	1000
			3	2,5	2	40	7650	6380	5260	4290	3450	2730	2110	1590	1150	780
			3	2,5	2	50	6740	5590	4590	3720	2970	2320	1770	1310	910	570
			3	3	3	30	10710	8960	7430	6090	4930	3930	3080	2360	1760	1250
			3,5	3	2,5	40	9560	7970	6570	5360	4310	3410	2640	1990	1440	975
	3,5		3	2,5	50	8430	6990	5740	4650	3710	2900	2220	1630	1140	710	
	5,5		4	3	30	15520	12990	10770	8830	7150	5700	4470	3420	2550	1820	
	5,5		5,5	4	40	13860	11550	9530	7770	6250	4940	3830	2890	2090	1410	
	5,5		5,5	4	50	12220	10130	8310	6730	5370	4210	3210	2370	1650	1030	
	4		4	3	30	16440	13760	11400	9340	7550	6020	4710	3600	2670	1890	
5,5	4	3	40	14630	12190	10050	8190	6580	5200	4020	3030	2180	1470			
5,5	5,5	4	50	12860	10660	8740	7080	5650	4420	3370	2480	1730	1080			
5,5	5,5	4	30	20550	17200	14250	11670	9440	7520	5880	4500	3340	2370			
7,5	5,5	4	40	18280	15230	12560	10240	8220	6500	5030	3780	2730	1840			
10	7,5	5,5	50	16070	13320	10930	8850	7060	5520	4220	3100	2160	1340			
7,5	5,5	5,5	30	24660	20640	17100	14000	11320	9020	7060	5400	4000	2840			
10	7,5	5,5	40	21940	18280	15070	12280	9870	7800	6030	4540	3270	2200			
10	7,5	5,5	50	19280	15990	13110	10620	8470	6630	5060	3720	2590	1610			
10	7,5	5,5	30	28190	23600	19570	16060	13010	10390	8160	6270	4690	3360			
10	10	7,5	40	25360	21170	17500	14310	11550	9180	7160	5450	4000	2770			
15	10	10	50	22610	18820	15510	12640	10170	8050	6240	4700	3390	2280			
10	10	7,5	30	35230	29500	24470	20070	16260	12990	10200	7840	5860	4200			
10	10	7,5	40	31700	26460	21880	17880	14430	11470	8950	6810	5000	3470			
10	10	10	50	28270	23530	19390	15800	12710	10060	7800	5880	4240	2840			
10	10	10	30	42280	35400	29360	24080	19510	15590	12240	9410	7030	5040			
15	15	10	40	38040	31750	26250	21460	17320	13770	10740	8170	6000	4160			
15	15	15	50	33920	28230	23270	18960	15250	12070	9360	7050	5090	3400			
15	15	15	30	47830	40050	33210	27240	22070	17630	13840	10640	7950	5700			
20	15	15	40	43030	35920	29700	24280	19590	15570	12150	9240	6790	4710			
20	20	15	50	38370	31940	26320	21450	17250	13650	10580	7980	5750	3850			
15	15	15	30	59790	50060	41510	34050	27590	22040	17300	13300	9940	7120			
20	15	15	40	53790	44900	37120	30340	24490	19470	15180	11550	8480	5880			
20	20	15	50	47970	39920	32900	26810	21560	17060	13230	9970	7190	4810			
20	20	20	30	71740	60070	49820	40860	33110	26450	20760	15960	11920	8540			
25	20	20	40	64540	53880	44540	36410	29390	23360	18220	13860	10180	7060			
25	25	20	50	57560	47910	39480	32170	25870	20470	15870	11960	8630	5770			
30	30	25	30	77490	64950	53930	44310	35980	28830	22730	17570	13230	9600			
40	30	25	40	70010	58530	48470	39710	32150	25660	20120	15430	11460	8100			
40	40	25	50	62740	52310	43210	35310	28510	22680	17720	13490	9890	6800			
30	25	20	30	112400	94170	78190	64250	52170	41800	32950	25470	19180	13920			
40	30	20	40	101600	84870	70280	57580	46610	37200	29180	22370	16620	11750			
40	40	25	50	90970	75850	62650	51200	41340	32890	25690	19560	14340	9860			
40	30	25	30	135600	113700	94370	77540	62970	50440	39770	30740	23150	16800			
50	40	30	40	122600	102500	84820	69500	56260	44900	35210	27000	20050	14180			
50	50	40	50	109800	91540	75610	61800	49890	39690	31000	23600	17310	11900			
30	25	20	30	89860	75320	62540	51390	41730	33430	26360	20370	15340	11130			
30	30	20	40	81200	67880	56210	46060	37280	29750	23340	17890	13290	9400			
40	30	25	50	72760	60670	50110	40960	33070	26310	20550	15640	11470	7890			
40	40	30	30	130300	109300	90680	74510	60510	48470	38220	29540	22250	16140			
50	40	30	40	117800	98420	81500	66780	54060	43140	33840	25940	19270	13620			
60	50	30	50	105500	87970	72660	59380	47940	38140	29790	22680	16630	11440			
50	50	40	30	157300	131900	109500	89930	73020	58500	46120	35650	26850	19480			
60	50	40	40	142100	118800	98370	80600	65240	52070	40840	31310	23260	16440			
60	50	40	50	127400	106200	87690	71670	57860	46030	35950	27370	20070	13800			
40	30	25	30	116300	97410	80890	66460	53970	43240	34090	26350	19840	14400			
40	40	25	40	105100	87790	72700	59570	48220	38480	30180	23140	17190	12150			
50	40	30	50	94100	78460	64810	52970	42770	34020	26570	20230	14830	10200			
50	40	40	30	168600	141300	117300	96370	78260	62690	49430	38200	28770	20880			
60	50	40	40	152300	127300	105500	86370	69920	55800	43760	33550	24920	17620			
60	50	40	50	136500	113800	93970	76800	62010	49330	38530	29340	21510	14790			
60	50	50	30	203400	170500	141600	116400	94450	75660	59650	46110	34720	25200			
75	60	50	40	183800	153700	127300	104300	84380	67340	52810	40500	30080	21260			
75	60	50	50	164700	137400	113500	92690	74840	59540	46500	35400	25960	17850			
40	30	25	30	134800	113000	93810	77080	62590	50150	39530	30560	23010	16700			
40	40	25	40	121800	101900	84310	69080	55920	44630	35000	26840	19940	14090			
50	40	30	50	109200	91000	75160	61430	49600	39460	30820	23460	17200	11830			
60	50	40	30	195500	163900	136100	111800	90760	72710	57320	44310	33370	24210			
75	60	40	40	176600	147700	122300	100200	81090	64710	50750	38910	28910	20430			
100	75	50	50	158300	132000	109000	89070	71910	57210	44680	34020	24940	17150			
75	60	50	30	235900	197800	164200	134900	109600	87750	69180	53470	40270	29220			
100	75	60	40	213200	178200	147600	120900	97860	78100	61250	46960	34880	24660			
100	100	60	50	191000	159300	131600	107500	86790	69050	53920	41060	30100	20700			
50	40	30	30	153700	128900	107000	87890	71370	57170	45070	34840	26230	19030			
50	50	40	40	138900	116100	96130	78760	63750	50880	39900	30590	22720	16050			
60	60	40	50	124500	103800	85680	70020	56530	44970	35110	26730	19590	13470			
60	60	40	30	222900	186800	155100	127500	103500	82900	65350	50510	38040	27600			
75	75	50	40	201400	168400	139400	114200	92440	73770	57850	44350	32940	23280			
100	75	60	50	180500	150500	124300	101600	81970	65200	50910	38760	28410	19530			
75	75	50	30	269000	225500	187200	153800	124900	100100	78870	60960	45900	33300			
100	100	60	40	243100	203200	168300	137900	111600	89030	69820	53520	39750	28090			
120	100	75	50	217800	181600	150000	122600	98920	78690	61440	46780	34280	23560			
50	50	40	30	178100	149300	123900	101800	82660	66220	52200	40350	30380	22040			
60	50	40	40	160900	134500	111400	91220	73840	58920	46210	35430	26310	18590			
75	60	50	50	144100	120200	99240	81100	65470	52080	40670	30960	22690	15600			
100	60	50	30	258200	216400	179700	147600	119900	96010	75690	58500	44050	31960			
100	75	60	40	233300	195000	161500	132300	107100	85440	67000	51370	38150	26960			
100	100	75	50	209000	174300	143900	117600</									

R404A
R507
2S-VS

Serie Range Serie Serie	Modello Model Modèle Typ	giri/1' r.p.m. tr / mn u.p.m.	Temp. Cond. Cond. Temp. Temp. Cond. Kond. Temp.	Q [W]	Capacità frigorifera Refrigerating capacity Puissance frigorifique Kälteleistung						
					Temperatura evaporazione / Evaporating temperature Température d'évaporation / Verdampfungstemperatur [°C]						
					[°C]	-25	-30	-35	-40	-45	-50
2S-VS Without Liquid Subcooler	2S-81VS	1450	30	38380	31660	25660	20370	16100	12500	9500	7070
			40	33510	27450	21850	16950	13380	10620	8090	6030
			50	28200	22840	18030	13590	10750	8380	6350	-
	2S-90VS	1450	30	44520	36720	29760	23630	18670	14490	11000	8200
			40	38860	31720	25340	19630	15510	12030	9170	6830
			50	32670	26490	20900	15750	12470	9700	7370	-

Serie Range Serie Serie	Modello Model Modèle Typ	giri/1' r.p.m. tr / mn u.p.m.	Temp. Cond. Cond. Temp. Temp. Cond. Kond. Temp.	Q [W]	Capacità frigorifera Refrigerating capacity Puissance frigorifique Kälteleistung						
					Temperatura evaporazione / Evaporating temperature Température d'évaporation / Verdampfungstemperatur [°C]						
					[°C]	-25	-30	-35	-40	-45	-50
2S-VS Without Liquid Subcooler	2S-81VS	1450	30	43770	37300	31260	25690	21030	16850	13230	10200
			40	41100	34850	28900	23250	19060	15250	12050	9280
			50	38500	32340	26510	20770	17120	13870	10920	-
	2S-90VS	1450	30	50750	43250	36250	29800	24400	19520	15350	11820
			40	47660	40420	33520	27000	22100	17700	13980	10760
			50	44680	37500	30750	24080	19840	16080	12650	-

R22
2S-VS**▪ Dati preliminari**

- Prestazioni con sottoraffreddamento del liquido
- Temperatura di aspirazione 20°C e 0K di sottoraffreddamento in uscita al condensatore
- Utilizzo con R22 solo dove permesso dalle legislazioni nazionali
- Non miscelare mai olii estere con olii differenti

▪ Preliminary data

- Performance data with liquid subcooling.
- 20°C suction gas temperature and 0K liquid subcooling at the outlet of the condenser
- Use with R22 only where permitted by national legislation
- Never mix ester oils with different oils

▪ Données préliminaires

- Données de puissance avec sous-refroidissement de liquide.
- 20°C de température du gaz d'aspiration et sous-refroidissement de liquide 0K au sortie du condenseur.
- Utiliser avec R22 seulement lorsque cela est autorisé par la législation nationale
- Ne mélanger jamais ester huiles avec different huiles

▪ Vorläufige Daten

- Leistungsdaten mit Flüssigkeitsunterkühlung.
- 20°C Sauggastemperatur und 0K Flüssigkeitsunterkühlung am Ausgang des Kondensators.
- Utiliser avec R22 seulement lorsque cela est autorisé par la législation nationale
- Niemals Esteröl mit anderen Ölen vermischen

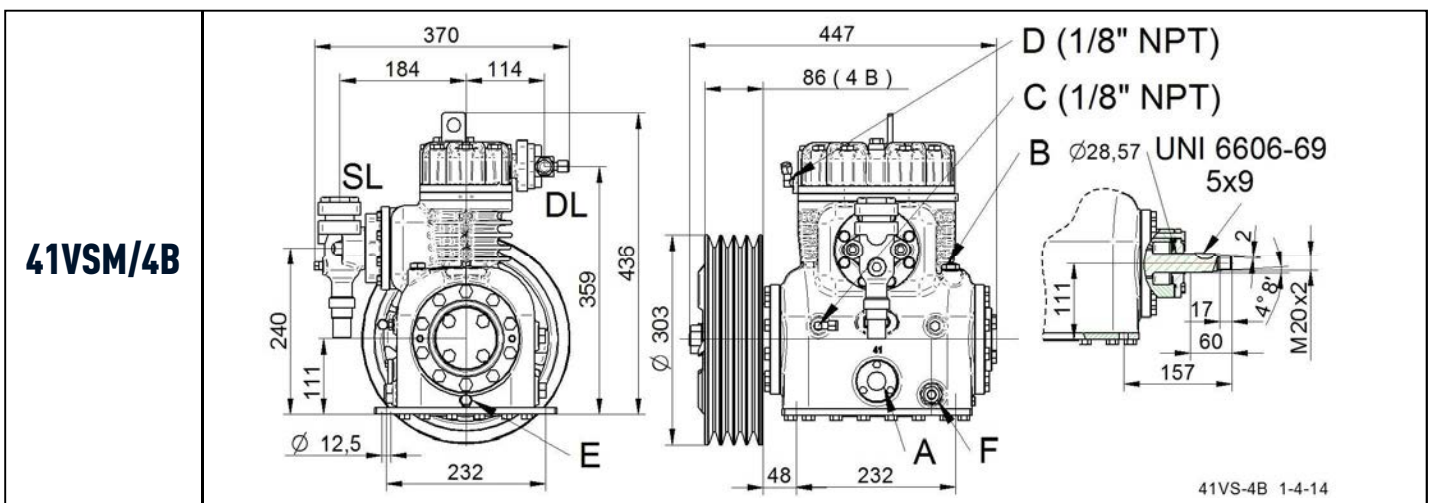
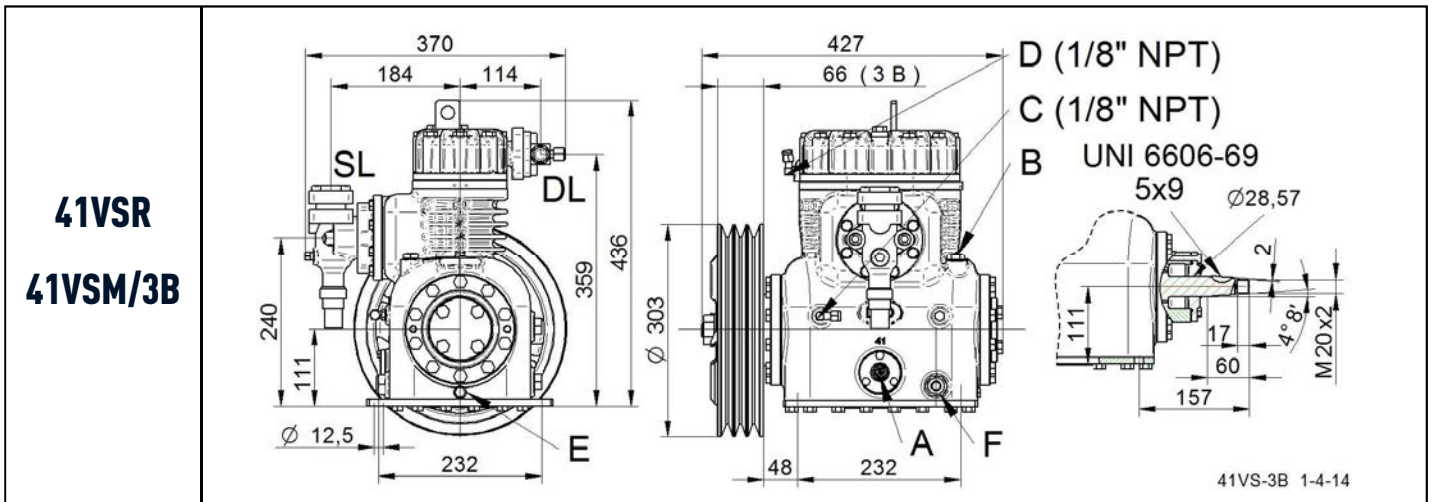
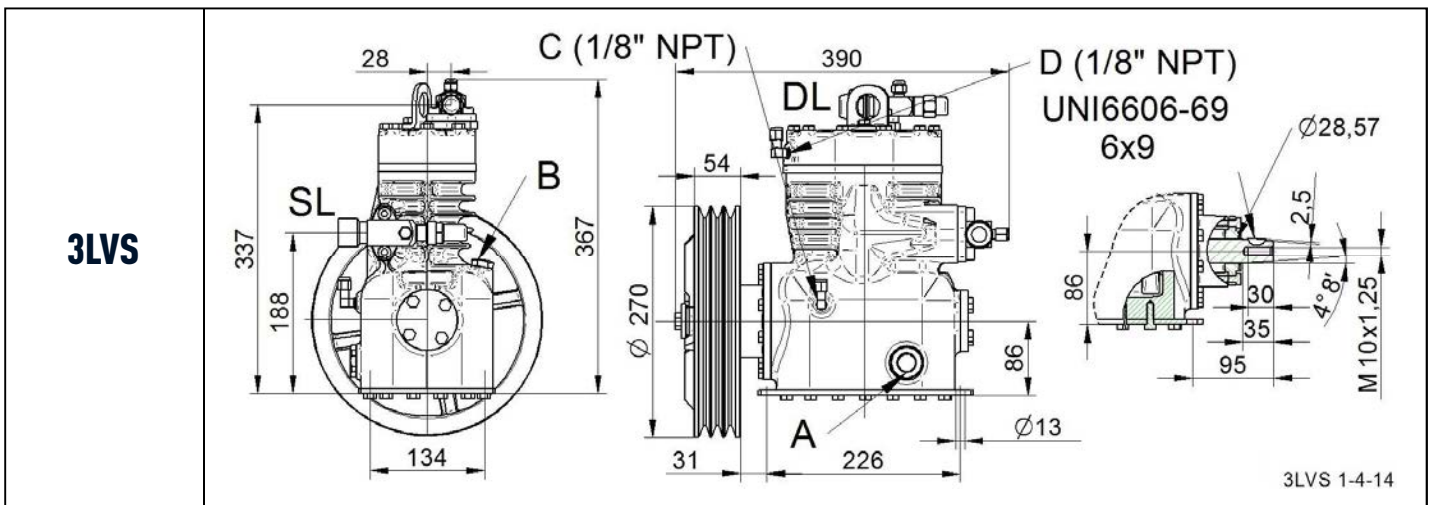
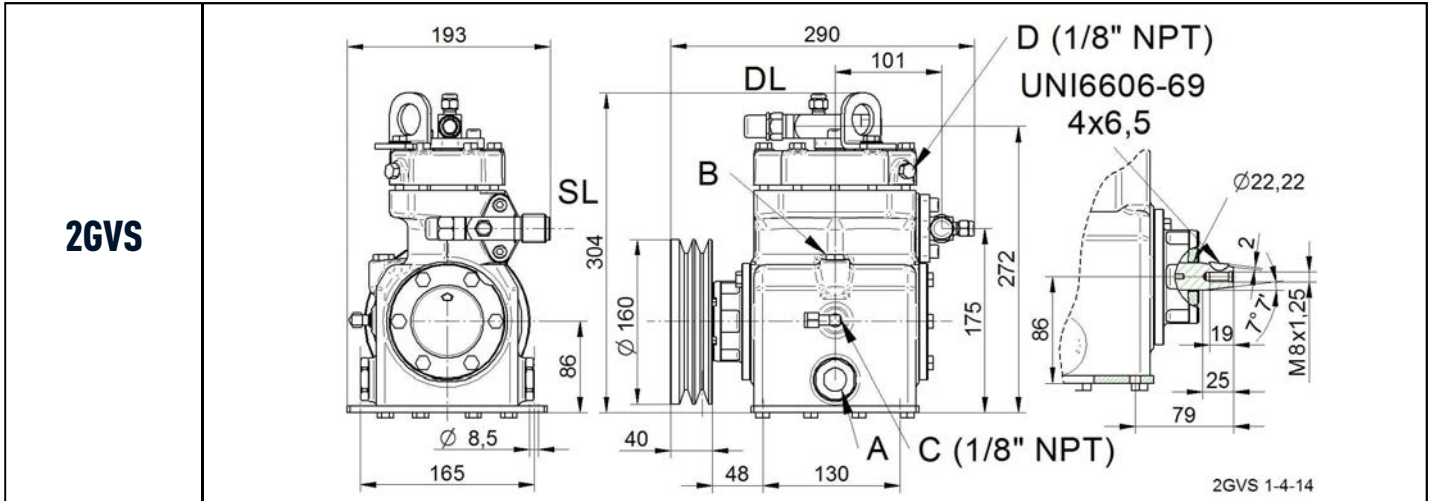

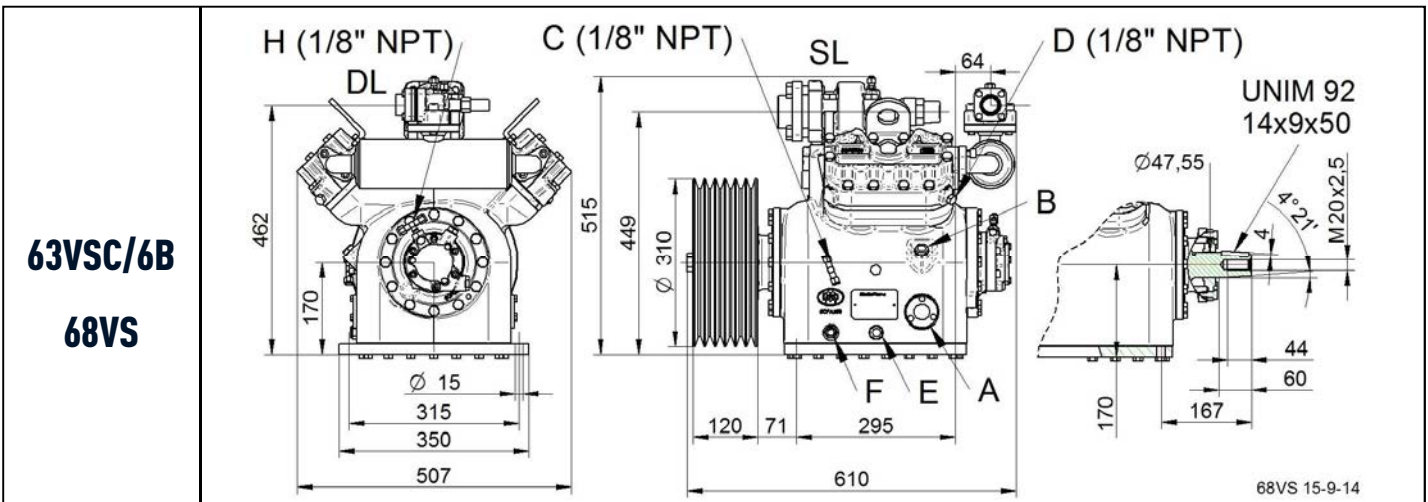
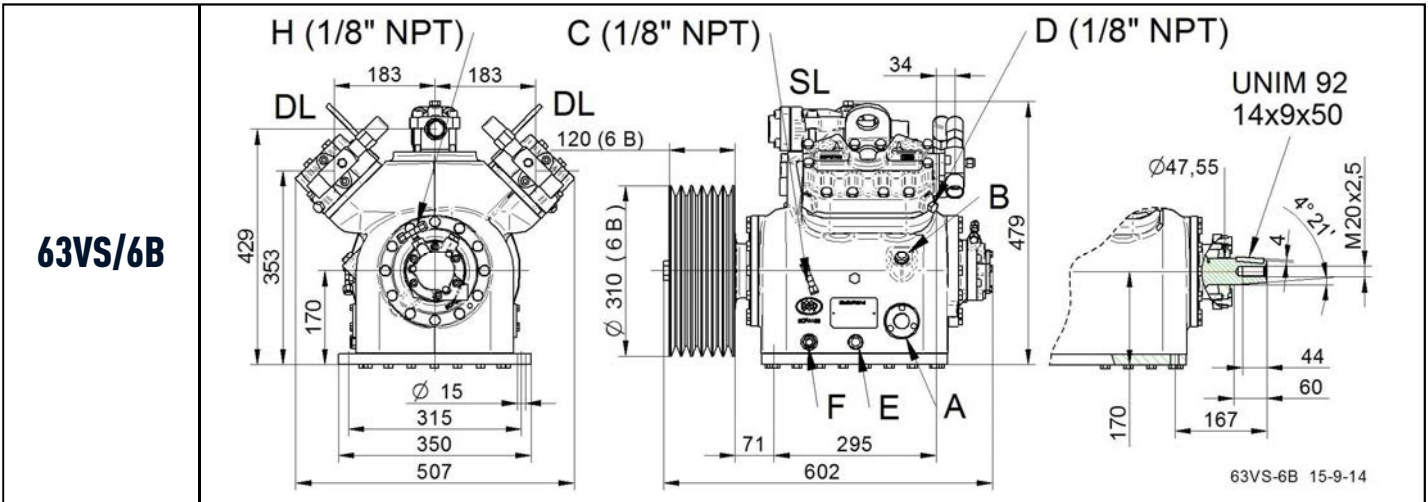
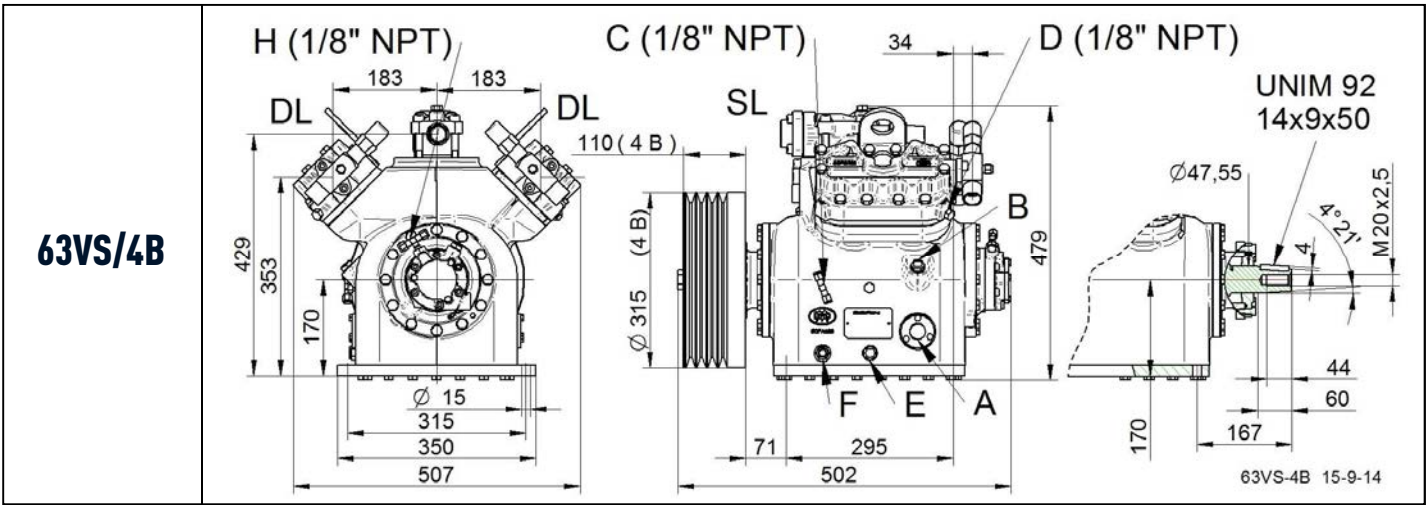
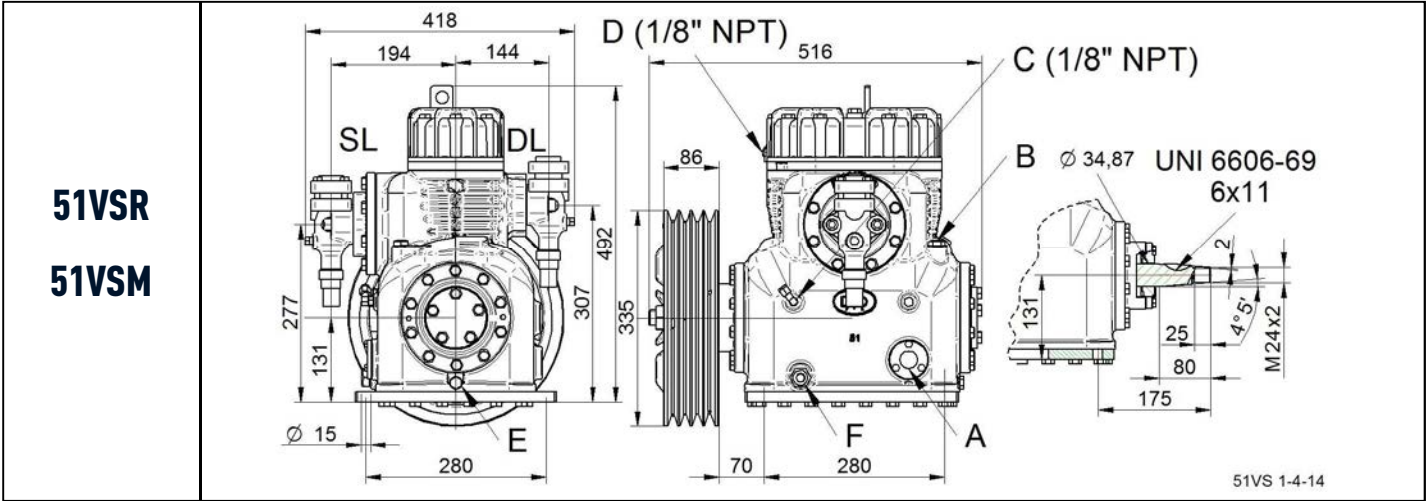

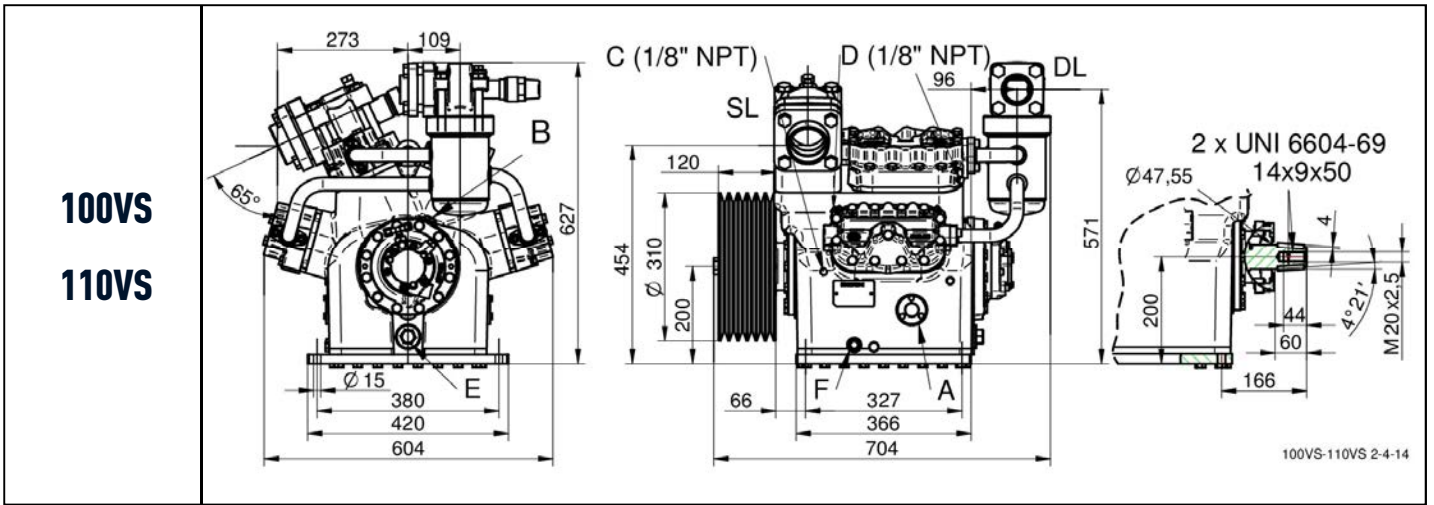
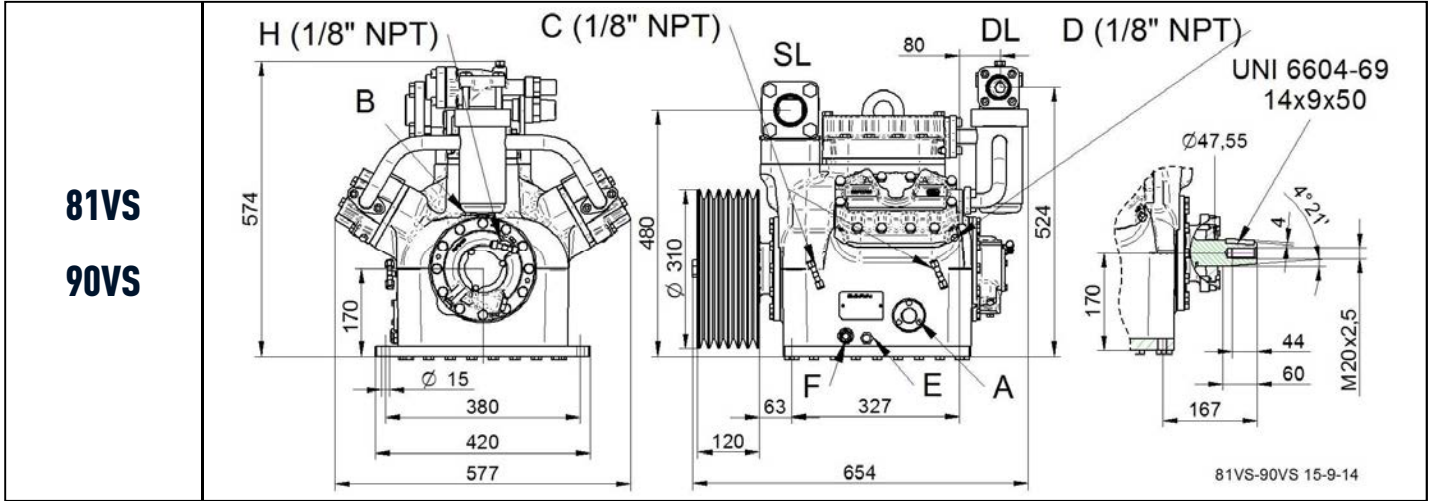

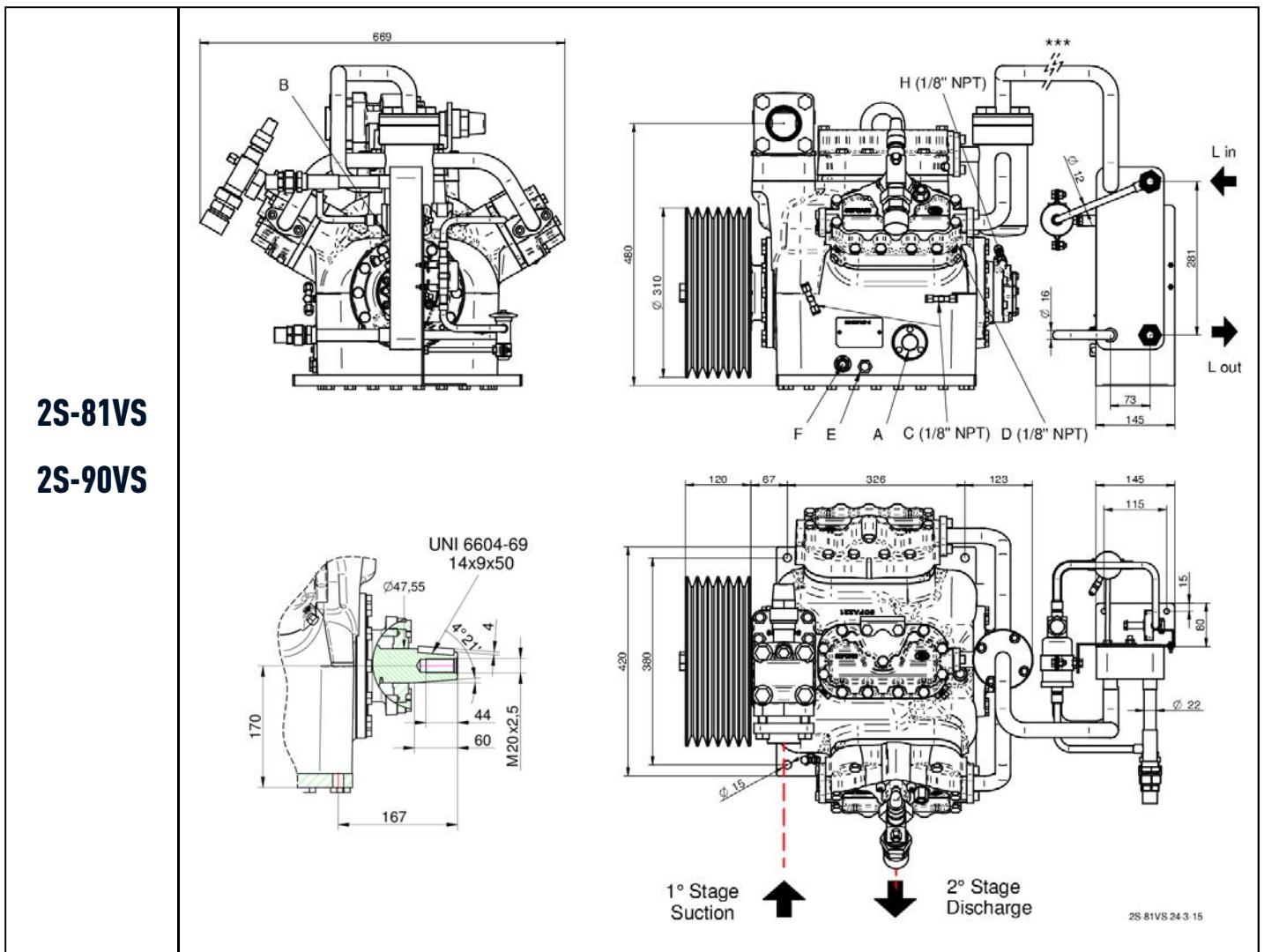

- Kit sottoraffreddatore fornito sciolto. Posizione definita dal cliente
- Subcooler kit supplied loose. Position defined by customer
- Kit de refroidisseur fourni lâche. Position définie par le client
- Unterkühler-Kit lose beigelegt. Position von Kunden definiert

- *** Linea di iniezione interstadio (non fornita)
- *** Interstage injection line (not supplied)
- *** Ligne d'injection intermédiaire (non fourni)
- *** Interseinspritzleitung (nicht mitgeliefert)

<p>A - Spia Olio B - Tappo carica Olio C - Presa Bassa Pres. D - Presa Alta Pres. E - Tappo scarica olio F - Resistenza carter H - Presa alta press. pompa DL - Rubinetto Compressione SL - Rubinetto Aspirazione Lin - Ingresso Liquido Lout - Uscita Liquido</p>	<p>A - Oil sight B - Oil charge plug C - Low pressure tap D - High pressure tap E - Oil drain plug F - Crankcase heater H - Oil pressure tap DL - Discharge service valve SL - Suction service valve Lin - Liquid Inlet Lout - Liquid outlet</p>	<p>A - Voyant d'huile B - Bouchon charge huile C - Prise basse pression D - Prise haute pression E - Bouchon vidange d'huile F - Resistance carter H - Prise pression huile DL - Vanne de refoulement SL - Vanne aspiration Lin - Entrée Liquide Lout - Sortie Liquide</p>	<p>A - Ölschauglas B - Ölfüllstopfen C - Anschluss Niederdruck D - Anschluss Hochdruck E - Öltaß F - Ölsumpheizung H - Öldruckanschluss DL - Druckabsperrventil SL - Saugabsperrventil Lin - Kältemittel-Eintritt Lout - Kältemittel-Austritt</p>
--	--	--	---



OFFICINE MARIO DORIN SINCE 1918
DORIN[®]
INNOVATION

OFFICINE MARIO DORIN S.p.A.
Via Aretina 388, 50061 Compiobbi - Florence, Italy
Tel. +39 055 62321 1 - Fax +39 055 62321 380

dorin@dorin.com
www.dorin.com